



# THE DOLPHIN



Proudly Sold & Serviced By:  
 Able Scale Co Pty Ltd  
 Ph: 1300 731 360  
 21 Green St Thomastown VIC. 3074

find us on the web: [www.ablescale.com.au](http://www.ablescale.com.au)

The new series of ADM Check Weighers are completely water proof to IP65 and manufactured from 304 Stainless Steel. The conveyor belts meet the requirements of HACCP.



There are two models in the ADM series, the 4404 and 4820. Each series has a standard & intelligent range of capacities, accuracies and speeds to meet any requirement.

The 4404 series has four models to choose from, 200 grams up to 1500 grams, maximum of 100 items per minute

*The 4820 series has eight models to choose from, starting at 100 grams up to 3000 grams, maximum of 250 items per minute.*

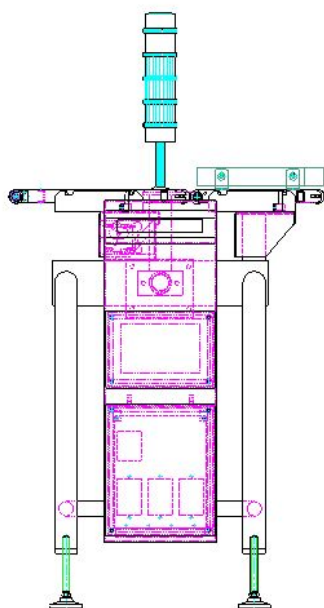

The 4404 series can store 100 individual product targets, simply recalled by an individual code number. It can also sort the products into 5 separate categories of HiHI, Hi, OK, Lo, LoLo.

### Available Options & Accessories:

- √ Metal Detector.
- √ Air Blast and Flipper rejection.
- √ 5 Color Sorting Lamps.
- √ Audible Error Alarm.
- √ RS232C Computer Interface.
- √ Printer Interface.
- √ Fieldbus Interface.
- √ Wireless data transmission



AD-8121 Statistical Printer

### Cleaning and Maintenance:

Both the Weigh and In-feed conveyors can be removed easily without the requirement of any tools, thus making cleaning and maintenance a very simple and quick task.

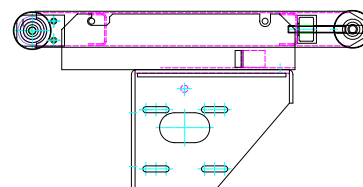

### Displayed Data:

Product Description, Total of pieces Checked, Total of pieces Accepted, Total of Pieces Rejected, Target, Under and Over Weights, Deviation Bar Graph, Average and Standard Deviation



Ph (08) 8301-8100 Fx (08) 8352-7409

VERSIONS	TD-200	TD-500	TD-1000	TD-1500
Range	2-200g	5-500g	10-1000g	15-1500g
Accuracy	± 0.2g	± 0.4g	± 0.6g	± 1.0g
Increment	0.05g	0.1g	0.2g	0.5g
Speed	60 p/min	50 p/min	40 p/min	30 p/min
Max Length	150mm	180mm	250mm	300mm
Max Width	100mm	120mm	220mm	220mm
Max Height	Min 5mm	Min 5mm	Min 5mm	Min 5mm
Power Cons	150VA	150VA	250VA	250VA
Power Supply	230VAC	± 10%	50/60Hz	415VA
Air Supply	0.5MP (5Kg/cm G) 0.1N,/min for Rejector			